

H.F./V.H.F. POWER TRANSISTOR

Silicon n-p-n power transistor for use in industrial and military s.s.b. and c.w. equipment operating in the h.f. and v.h.f. band:

- rated for 150 W P.E.P. at 1,6 MHz to 28 MHz
(intermodulation distortion better than 30 dB down)
- rated at 150 W output power for frequencies up to 108 MHz in c.w. operation
- supply voltage up to 50 V
- plastic encapsulated stripline package
- delivered in matched h_{FE} groups

QUICK REFERENCE DATA

mode of operation	V_{CE} V	f MHz	P_L W	G_p dB	d_3 dB	$I_{C(ZS)}$ A
s.s.b. (class-AB)	50	1,6 to 28	20 to 150 (P.E.P.)	> 14	< -30	0,10
s.s.b. (class-A)	40	1,6 to 28	typ. 30 (P.E.P.)	> 14	< -40	2,5
c.w. (class-B)	50	70	150	> 10	—	—
c.w. (class-B)	50	108	150	typ. 7,4	—	—

MECHANICAL DATA

Dimensions in mm

Fig. 1 SOT-55.

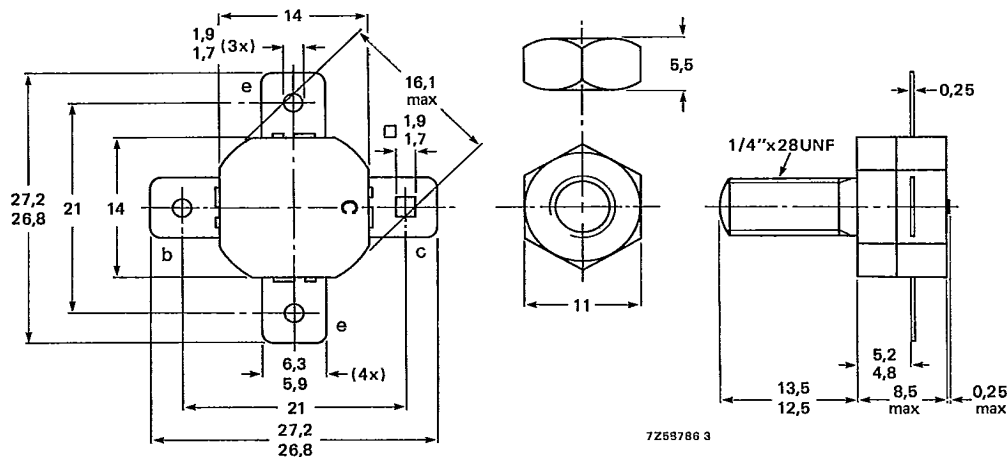

When locking is required an adhesive is preferred instead of a lock washer.

Torque on nut: min. 2,3 Nm
(23 kg cm)
max. 2,7 Nm
(27 kg cm)

Diameter of clearance hole in heatsink: max. 6,4 mm.
Mounting hole to have no burrs at either end.
De-burring must leave surface flat; do not chamfer
or countersink either end of hole.

PRODUCT SAFETY This device incorporates beryllium oxide, the dust of which is toxic. The device is entirely safe provided that the BeO disc is not damaged.

RATINGS Limiting values in accordance with the Absolute Maximum System (IEC134)

Collector-base voltage (open emitter) peak value	V_{CBOM}	max.	110 V
Collector-emitter voltage ($R_{BE} = 10\Omega$) peak value	V_{CERM}	max.	110 V
Collector-emitter voltage (open base)	V_{CEO}	max.	53 V
Emitter-base voltage (open collector)	V_{EBO}	max.	4,0 V
Collector current (average)	$I_C(AV)$	max.	6,5 A
Collector current (peak value) $f > 1$ MHz	I_{CM}	max.	20 A

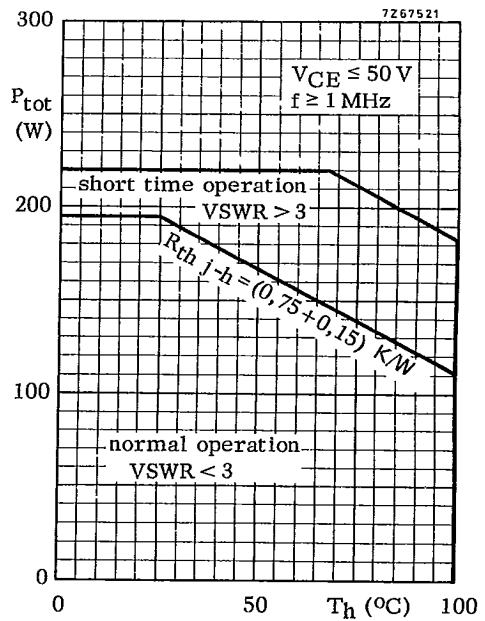
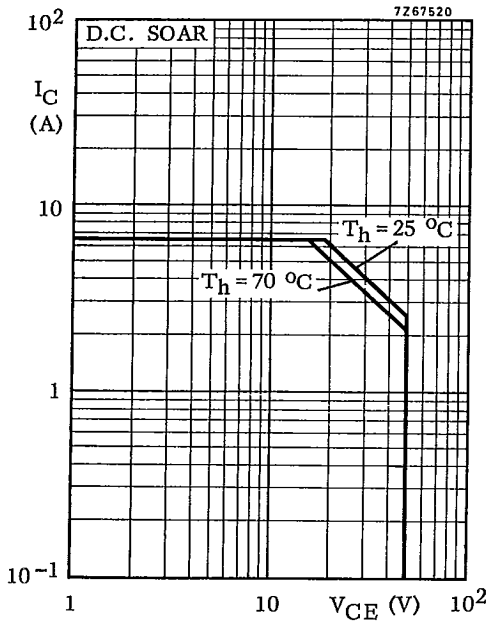

Storage temperature
Junction temperature

T_{stg}	-65 to +200 °C
T_j	max. 200 °C

THERMAL RESISTANCE

From junction to mounting base
From mounting base to heatsink

$R_{th j-mb}$	=	0,75 K/W
$R_{th mb-h}$	=	0,15 K/W

CHARACTERISTICS

$T_j = 25\text{ }^\circ\text{C}$ unless otherwise specified

Breakdown voltages

Collector-base voltage open emitter ; $I_C = 100\text{ mA}$	$V_{(BR)CBO}$	>	110	V
Collector-emitter voltage $R_{BE} = 5\ \Omega$; $I_C = 100\text{ mA}$	$V_{(BR)CER}$	>	110	V
Collector-emitter voltage open base ; $I_C = 100\text{ mA}$	$V_{(BR)CEO}$	>	53	V
Emitter-base voltage open collector; $I_E = 20\text{ mA}$	$V_{(BR)EBO}$	>	4,0	V

Transient energy

$L = 25\text{ mH}$; $f = 50\text{ Hz}$

open base	E	>	12,5	ms
$-V_{BE} = 1,5\text{ V}$; $R_{BE} = 33\ \Omega$	E	>	12,5	ms

D.C. current gain

$I_C = 1,4\text{ A}$; $V_{CE} = 6\text{ V}$	h_{FE}		15 to 50	
--	----------	--	----------	--

D.C. current gain ratio of matched devices

$I_C = 1,4\text{ A}$; $V_{CE} = 6\text{ V}$	h_{FE1}/h_{FE2}	<	1,2	
--	-------------------	---	-----	--

Transition frequency

$I_C = 6,0\text{ A}$; $V_{CE} = 35\text{ V}$	f_T	typ.	275	MHz
---	-------	------	-----	-----

Collector capacitance at $f = 1\text{ MHz}$

$I_E = I_e = 0$; $V_{CB} = 50\text{ V}$	C_c	typ.	185	pF
		<	220	pF

Feedback capacitance at $f = 1\text{ MHz}$

$I_C = 150\text{ mA}$; $V_{CE} = 50\text{ V}$	C_{re}	typ.	115	pF
--	----------	------	-----	----

Collector-stud capacitance

	C_{cs}	typ.	3,5	pF
--	----------	------	-----	----

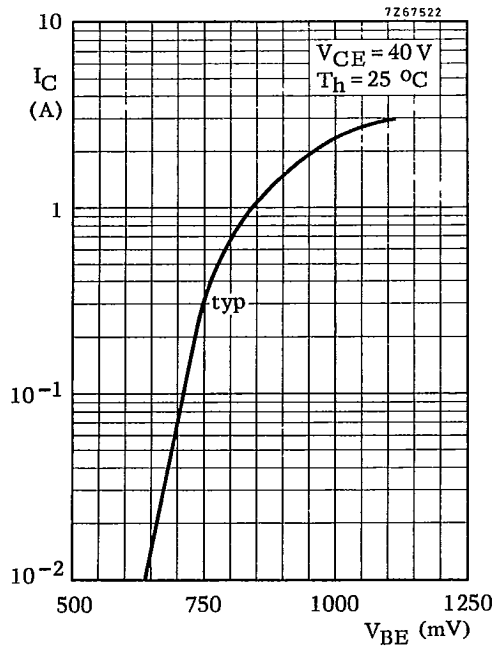
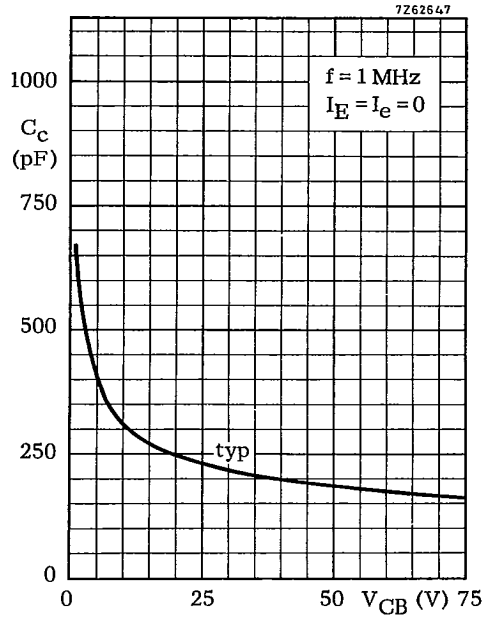
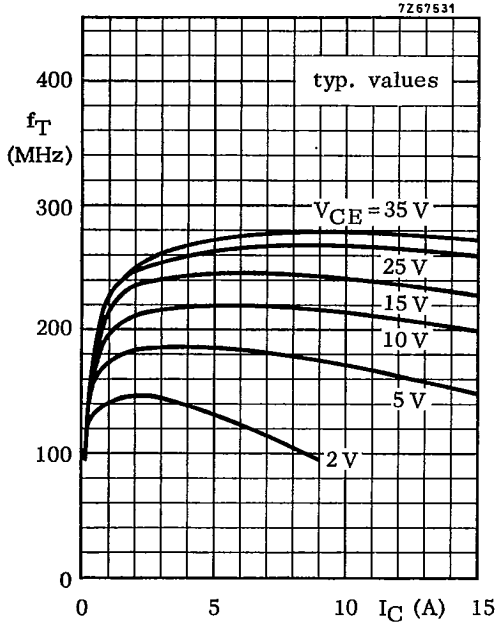

APPLICATION INFORMATION

R.F. performance in s.s.b. operation (linear power amplifier)

T_h up to 25 °C

$f_1 = 28,000$ MHz; $f_2 = 28,001$ MHz

output power (W)	G_p (dB)	η_{dt} (%)	d_3 (dB) 1)	d_5 (dB) 1)	I_{CZS} (A)	I_C (A)	V_{CE} (V)	Class
20 to 150 (PEP)	> 14	> 37,5	< -30	< -30	0,10	< 4	50	AB
typ. 30 (PEP)	> 14	typ. 15	< -40	< -40	2,5	-	40	A

S.S.B. test circuit class AB; $f = 28$ MHz

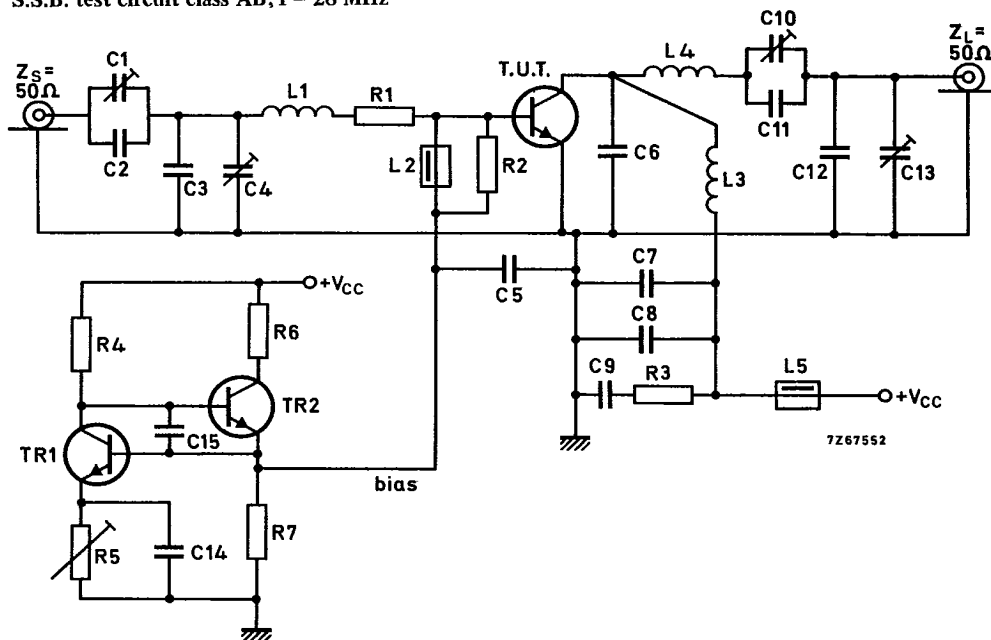

List of components: see next page.

1) Stated figures are maxima encountered at any driving level between the specified values of PEP and are referred to the according level of either of the equal amplified tones. Relative to the according peak envelope power these figures should be increased by 6 dB.

APPLICATION INFORMATION (continued)

List of components:

Tr1 = BD135
Tr2 = BD228

C1 = C10 = 100 pF air dielectric capacitor (single insulated rotor type)
C2 = C6 = 27 pF ceramic capacitor
C3 = 180 pF ceramic capacitor
C4 = C13 = 100 pF air dielectric capacitor (single non-insulated rotor)
C5 = C7 = 3,9 nF polyester capacitor ($\pm 10\%$)
C8 = C14 = C15 = 100 nF polyester capacitor ($\pm 10\%$)
C9 = 2,2 μ F moulded metallized polyester capacitor
C11 = 68 pF ceramic capacitor
C12 = 220 pF ceramic capacitor

L1 = 88 nH; 3 turns Cu wire (1,0 mm); internal diameter 9 mm; coil length 6,1 mm;
leads 2 x 5 mm

L2 = L5 = ferroxcube bead, grade 3B (code number 4312 020 36640)

L3 = 180 nH; 4 turns enamelled Cu wire (1,5 mm); internal diameter 12 mm;
coil length 9,9 mm; leads 2 x 10 mm

L4 = 350 nH; 7 turns enamelled Cu wire (1,5 mm); internal diameter 12 mm;
coil length 19,1 mm; leads 2 x 10 mm

R1 = 0,66 Ω parallel connection of 5 x 3,3 Ω carbon resistors ($\pm 5\%$; 0,5 W each)

R2 = 27 Ω carbon resistor ($\pm 5\%$; 0,5 W)

R3 = 4,7 Ω carbon resistor ($\pm 5\%$; 0,5 W)

R4 = 5,6 k Ω carbon resistor ($\pm 5\%$; 1 W)

R5 = 15 Ω wire-wound potentiometer (3W)

R6 = 157 Ω parallel connection of 3 x 470 Ω wire-wound resistors (5,5W each)

R7 = 68 Ω carbon resistor ($\pm 5\%$; 0,5 W)

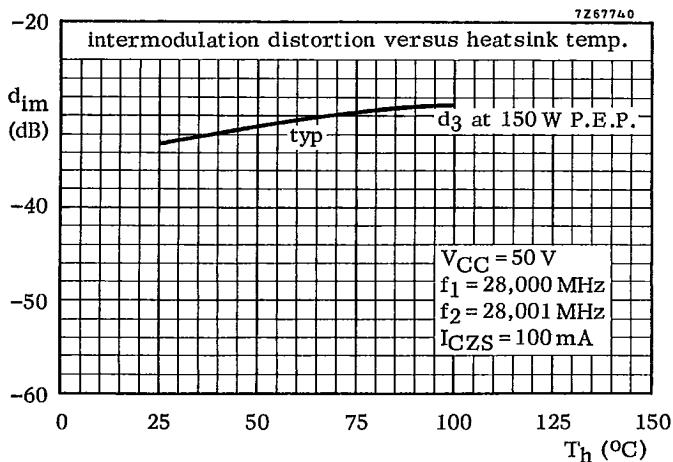

PHILIPS INTERNATIONAL

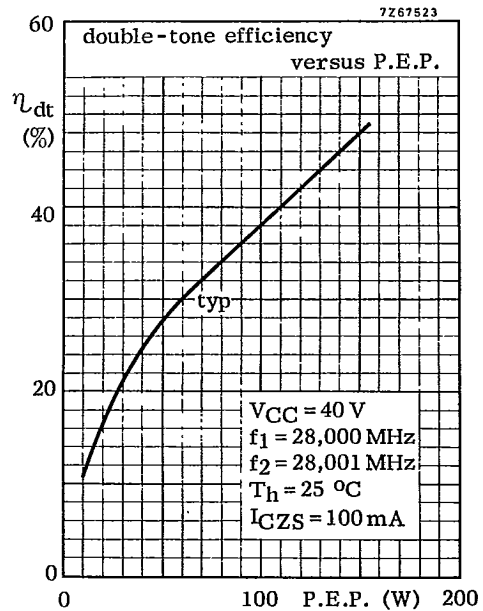
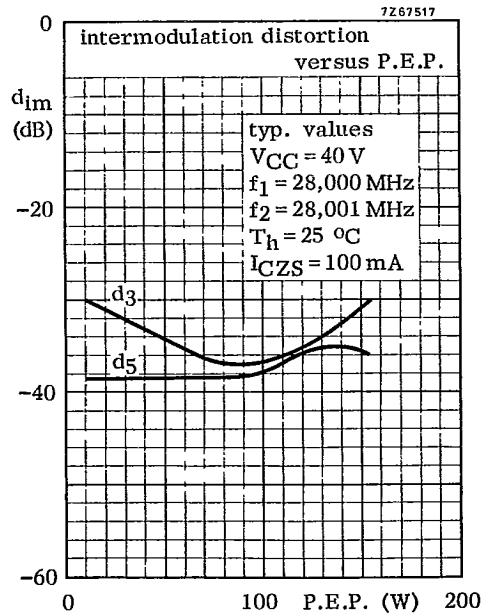
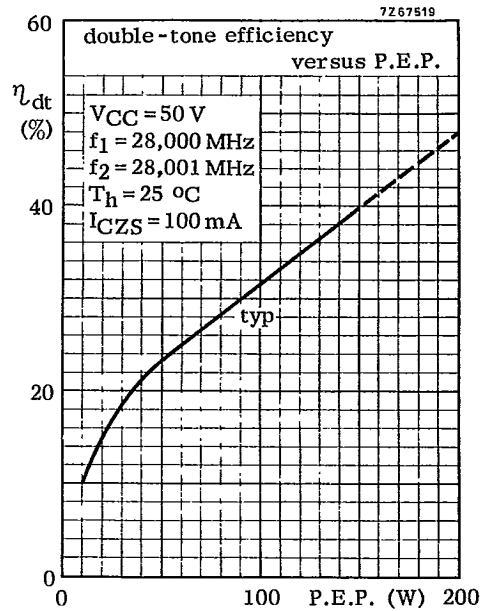
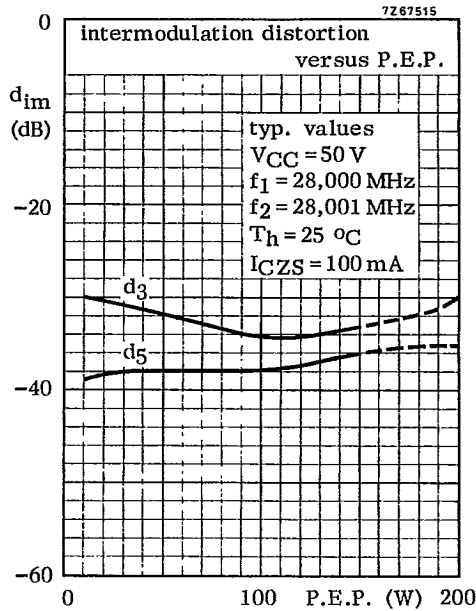

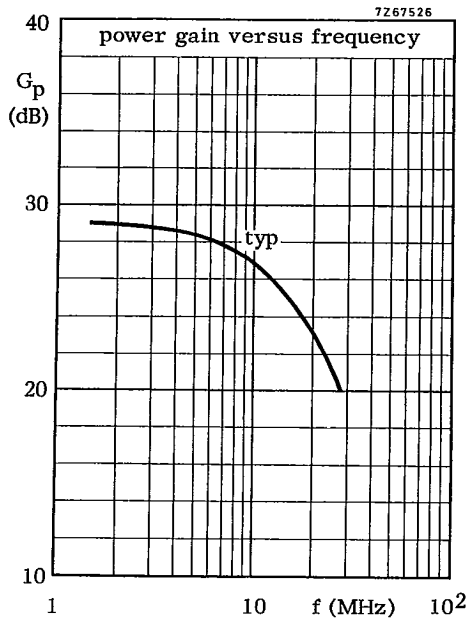
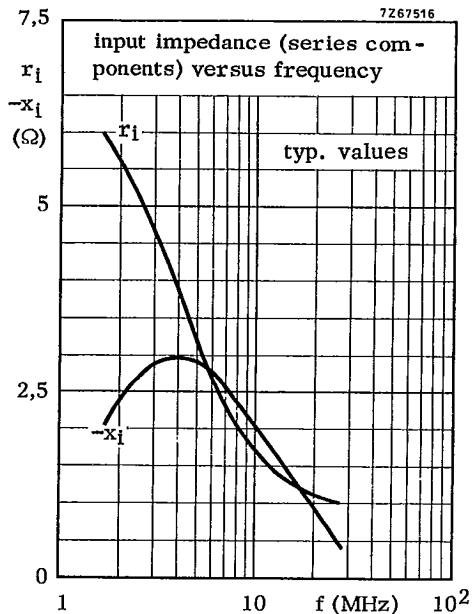

S.S.B. class AB operation

$P_L = 150 \text{ W (PEP)}$

$V_{CC} = 50 \text{ V}$

$I_{CZS} = 100 \text{ mA}$

$T_h = 25 \text{ }^\circ\text{C}$

$Z_L = 6,25 \text{ } \Omega$ in series with $10,4 \text{ nH}$ (in parallel with -267 pF)

The graphs hold for one transistor of a push-pull amplifier with cross neutralization; collector ($Tr1$) - base ($Tr2$), neutralizing capacitor: 82 pF .

PHILIPS INTERNATIONAL

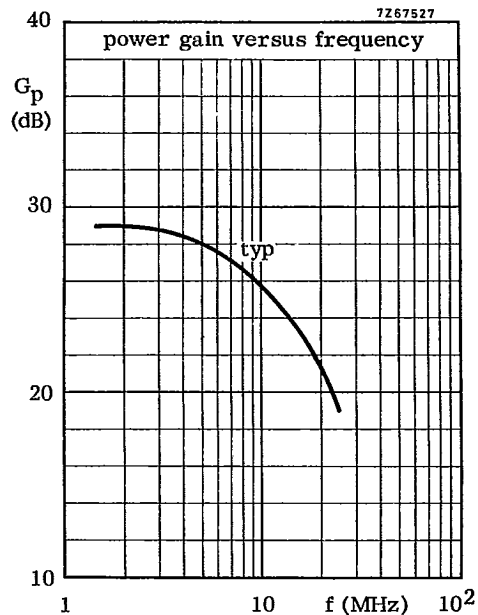
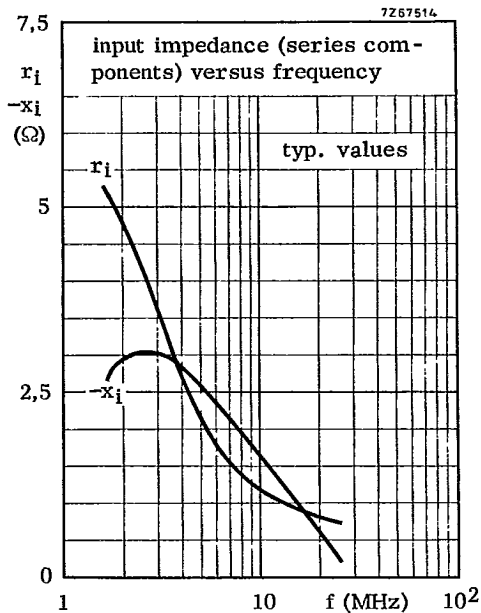

S.S.B. class AB operation

$P_L = 150$ W (PEP)

$V_{CC} = 50$ V

$I_{CZS} = 100$ mA

$T_h = 25$ °C

$Z_L = 6,25$ Ω in series with 7,3 nH (in parallel with -188 pF)

The graphs hold for an unneutralized amplifier.

APPLICATION INFORMATION (continued)

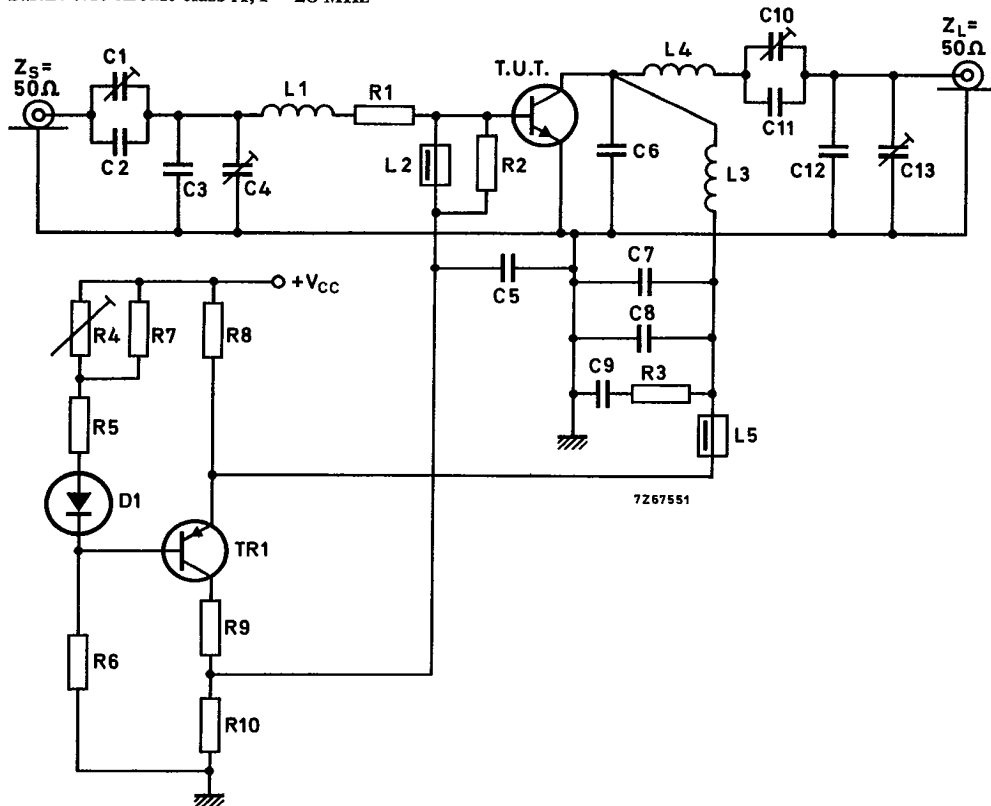
S.S.B. test circuit class-A; $f = 28 \text{ MHz}$ 

List of components:

D1 = BY206

TR1 = BD204

C1 = C10 = 100 pF air dielectric capacitor (single insulated rotor type)

C2 = C6 = 27 pF ceramic capacitor

C3 = 180 pF ceramic capacitor

C4 = C13 = 100 pF air dielectric capacitor (single non-insulated rotor)

C5 = C7 = 3,9 nF polyester capacitor ($\pm 10\%$)C8 = 100 nF polyester capacitor ($\pm 10\%$)C9 = 2,2 μF moulded metallized polyester capacitor

C11 = 68 pF ceramic capacitor

C12 = 220 pF ceramic capacitor

PHILIPS INTERNATIONAL

APPLICATION INFORMATION (continued)

List of components: (continued)

- L1 = 88 nH; 3 turns Cu wire (1,0 mm); internal diameter 9 mm; coil length 6,1 mm; leads 2 x 5 mm
- L2 = L5 = ferroxcube bead, grade 3B (code number 4312 020 36440)
- L3 = 180 nH; 4 turns enamelled Cu wire (1,5 mm); internal diameter 12 mm; coil length 9,9 mm; leads 2 x 10 mm
- L4 = 350 nH; 7 turns enamelled Cu wire (1,5 mm); internal diameter 12 mm; coil length 19,1 mm; leads 2 x 10 mm

- R1 = 0,66 Ω parallel connection of 5 x 3,3 Ω carbon resistors ($\pm 5\%$; 0,5 W each)
- R2 = 27 Ω carbon resistor ($\pm 5\%$; 0,5 W)
- R3 = 4,7 Ω carbon resistor ($\pm 5\%$; 0,5 W)
- R4 = 50 Ω wire-wound potentiometer (1 W)
- R5 = 10 Ω carbon resistor ($\pm 5\%$; 1 W)
- R6 = 560 Ω enamelled wire-wound resistor (5,5 W)
- R7 = 270 Ω carbon resistor ($\pm 5\%$; 1 W)
- R8 = 0,6 Ω parallel connection of 3 x 1,8 Ω wire-wound resistors (8 W each)
- R9 = 90 Ω parallel connection of 3 x 270 Ω enamelled wire-wound resistor (5,5 W each)
- R10 = 12 Ω carbon resistor ($\pm 5\%$; 1 W)

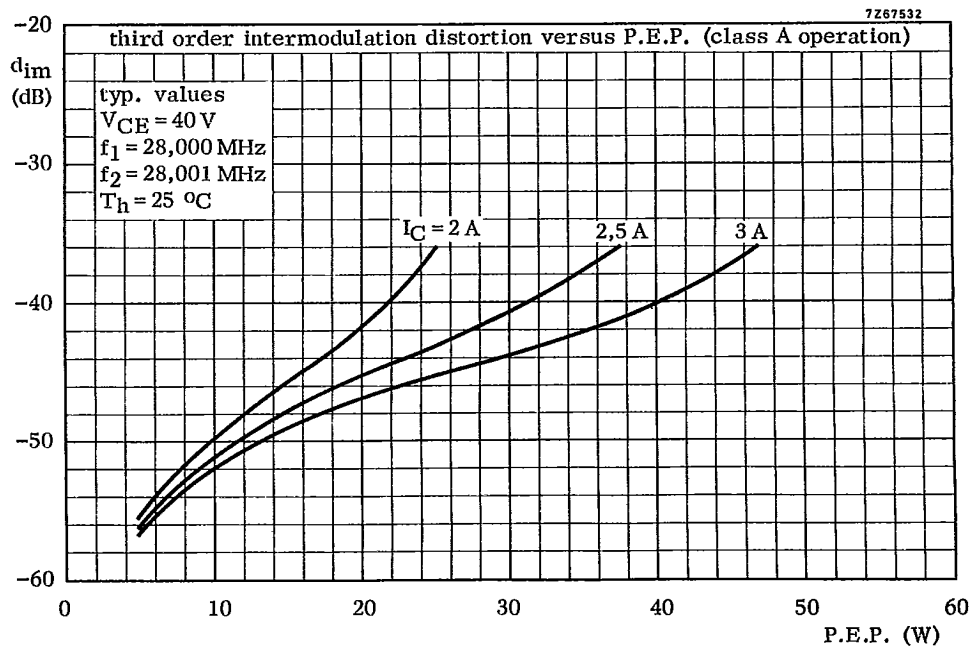

APPLICATION INFORMATION (continued)

R.F. performance in c.w. operation (class-B circuit)

 $V_{CE} = 50 \text{ V}$; T_h up to $25 \text{ }^\circ\text{C}$

f (MHz)	P_S (W)	P_L (W)	I_C (A)	G_p (dB)	η (%)
70	< 15	150	< 4,6	> 10	> 65
108	typ. 27	150	typ. 4,0	typ. 7,4	typ. 75

Test circuit: 70 MHz; c.w. class-B.

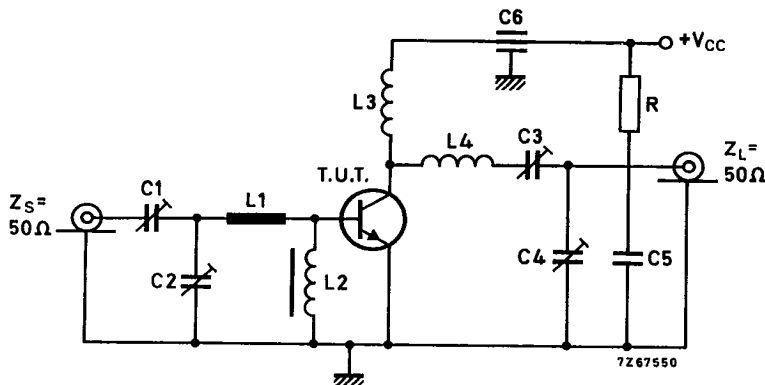

List of components:

L1 = 60 mm straight enamelled Cu wire (1,6 mm); 9 mm above chassis

L2 = Ferroxcube wide-band h.f. choke, grade 3B (cat. no. 4312 020 36640)

L3 = 18 turns enamelled Cu wire (1,6 mm); internal diameter 10 mm; pitch 2 mm; leads 55 mm totally

L4 = 3 turns enamelled Cu wire (1,6 mm); internal diameter 10 mm; pitch 2,5 mm; leads 50 mm totally

C1 = 4 to 29 pF concentric air trimmer in parallel with 10 pF ceramic capacitor

C2 = 4 to 104 pF film dielectric trimmer in parallel with 56 pF ceramic capacitor

C3 = 4 to 104 pF film dielectric trimmer

C4 = 4 to 104 pF film dielectric trimmer in parallel with 47 pF ceramic capacitor

C5 = 100 nF polyester capacitor ($\pm 10\%$)

C6 = 1 nF ceramic feed-through capacitor

R = 10 Ω carbon resistor (0,5 W)At $P_L = 150 \text{ W}$ and $V_{CE} = 50 \text{ V}$, the output power at heatsink temperatures between $25 \text{ }^\circ\text{C}$ and $75 \text{ }^\circ\text{C}$ relative to that at $25 \text{ }^\circ\text{C}$ is diminished by 100 mW/K.

PHILIPS INTERNATIONAL

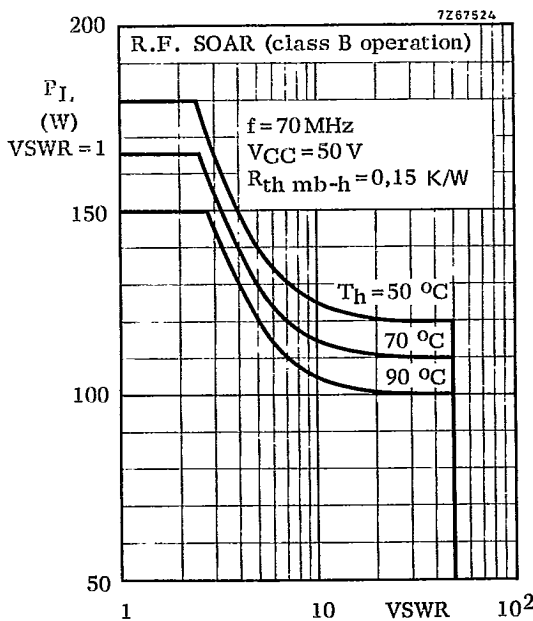
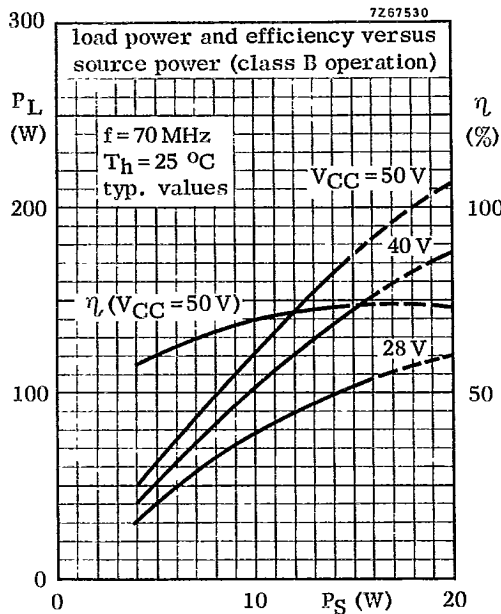

Indicated load power as a function of overload.

The graph has been derived from an evaluation of the performance of transistors matched up to 180 W load power in the test amplifier and subsequently subjected to various mismatch conditions at 50 V with VSWR up to 50 and elevated heatsink temperatures.

This indicates a restriction to the load power matched under nominal conditions in the recommended test configuration.

APPLICATION INFORMATION (continued)

Test circuit:

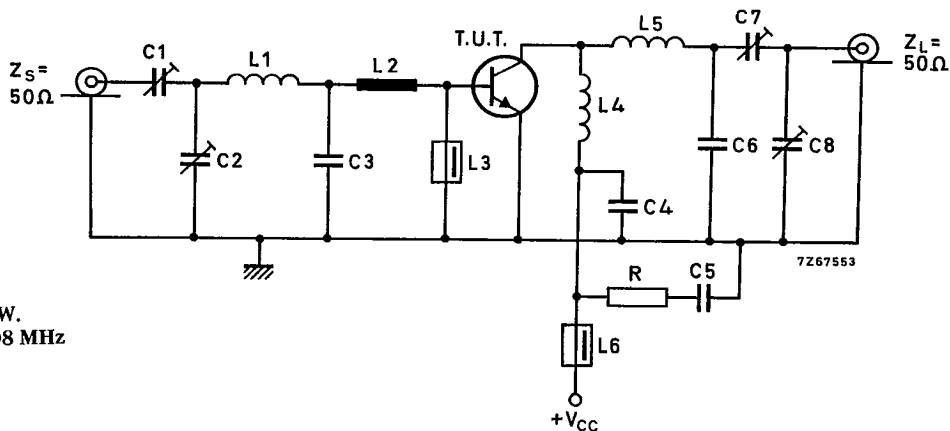

C.W.
108 MHz

List of components:

- C1 = C2 = 40 pF film dielectric trimmer
 C3 = 400 pF parallel connection of 4 x 100 pF ceramic capacitors
 C4 = 270 pF ceramic capacitor
 C5 = 100 nF polyester capacitor ($\pm 10\%$)
 C6 = 20 pF parallel connection of 2 x 10 pF ceramic capacitors
 C7 = C8 = 60 pF film dielectric trimmer
 L1 = 49 nH; 2 turns enamelled Cu wire (1,5 mm); internal diameter 9 mm; coil length 4,8 mm; leads 2 x 5 mm
 L2 = strip-line (7,7 mm x 6 mm); tap for C3 is 7,5 mm from transistor edge
 L3 = L6 = ferroxcube bead, grade 3B (code number 4312 020 36640)
 L4 = 67 nH; 3 turns enamelled Cu wire (1,5 mm); internal diameter 8 mm; coil length 8,3 mm; leads 2 x 5 mm
 L5 = 57 nH; 2 turns enamelled Cu wire (1,5 mm); internal diameter 10 mm; coil length 4,5 mm; leads 2 x 5 mm
 R = 10 Ω carbon resistor (0,5 W)

PHILIPS INTERNATIONAL

APPLICATION INFORMATION (continued)

Component lay-out and printed circuit board for 108 MHz test circuit.

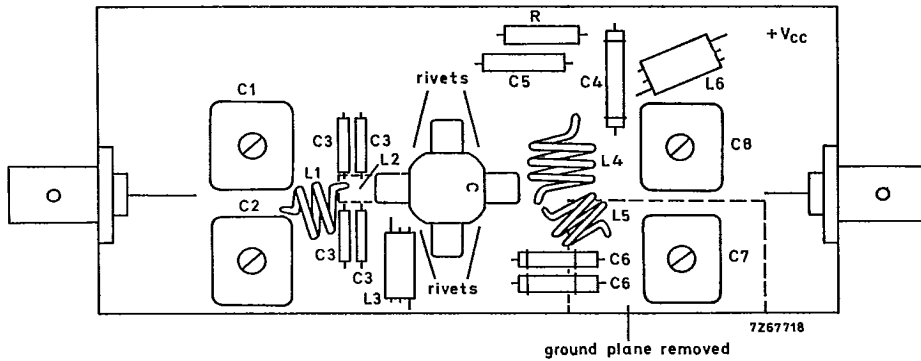

Dimensions of printed circuit board 123 mm x 55 mm.

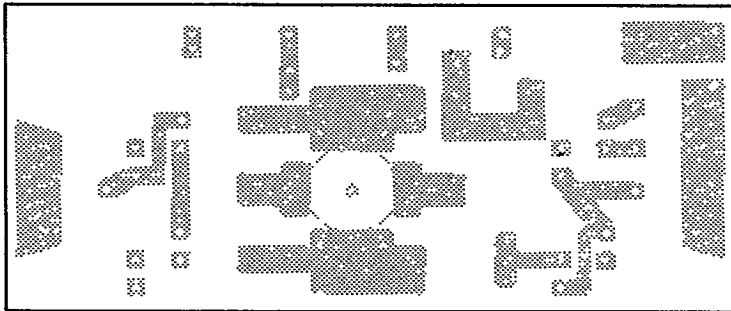

The circuit has been built on epoxy fibre-glass double copper clad printed circuit board (thickness 1/16"). To minimize the dielectric losses, the ground plane under the inter-connection of L5, C6 and C7 has been removed.

